



Superior Magnetics Since 1979



CMMI-8B3

Microphone Input Transformer 1 : 8 Step-up

- Good bandwidth (- 3 dB at 65 kHz)
- Excellent CMRR: 105 dB at 60 Hz
- 17.8 dB voltage step-up; 1 :8 turn ratio
- Low profile package
- PC mount and lead versions

The CineMag CMMI-8B3 microphone input transformer follows classic designs. It is intended for medium input impedance amplifiers. It exhibits good bandwidth, common mode rejection ratio (CMRR), and distortion characteristics. The CMMI-8B3 is a cost-effective p.c. or wire lead device. It is widely used in professional grade designs. It is encased in a μ Metal can which provides 30 dB of magnetic shielding. As with all CineMag transformers, the wires from the internal foil shields between windings are all spot welded for maximum long term reliability.

This transformer has a moderately high impedance secondary. Care must be exercised in the design of the amplifier that it drives to obtain best results and to realize good bandwidth.

CMMI-8B3 / CMMI-8B3-PC

Parameter	Conditions	Typ
Turns Ratio		1 : 8.0
Voltage Gain	1 kHz, -20 dBu 150 Ω input, 100K secondary load impedance	17.8 dB
Distortion (THD+N%)	1 kHz, -10 dBu Test Circuit 1 20 Hz, -20 dBu Test Circuit 1	0.002% 0.06%
Max 20 Hz input level	1.0% THD; 150 Ω input, 100K secondary load impedance Test Circuit 1	-1 dBu
Response, ref 1 kHz	20 Hz Test Circuit 1 20 kHz Test Circuit 1 -3 dB	-0.20 dB +0.25 dB 65 kHz
Phase Shift at 20 Hz Phase Shift at 20 kHz	Referenced to source generator Test Circuit 1	+5° -20°
CMRR	60 Hz Test Circuit 2 per IEEE Std 389-1996 ¶19 1 kHz Test Circuit 2 per IEEE Std 389-1996 ¶19	105 dB 82 dB
Operating Temp Range	Operation and storage	0° C Min 70° C Max
Max Soldering Temp (p.c.)	5 Seconds	335° C Max

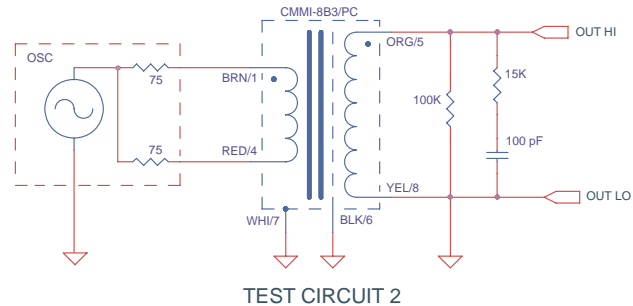
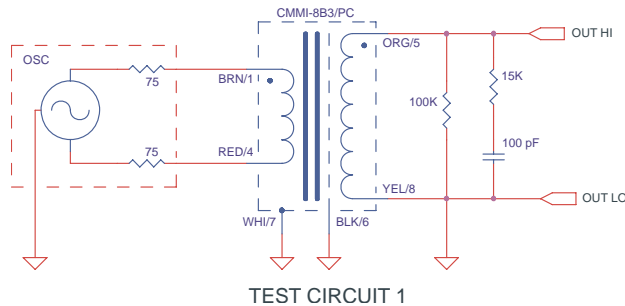
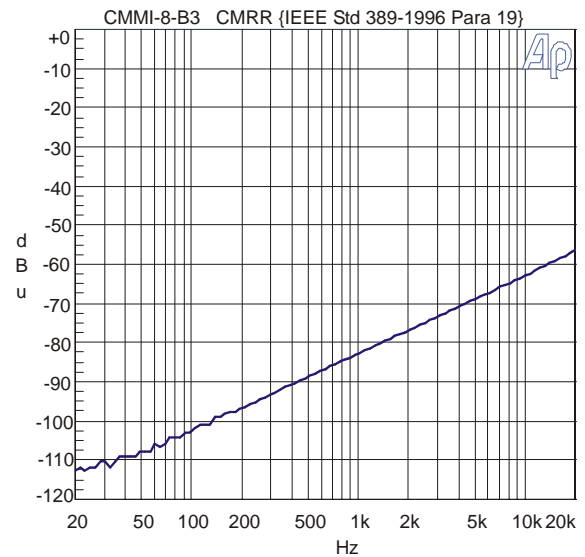
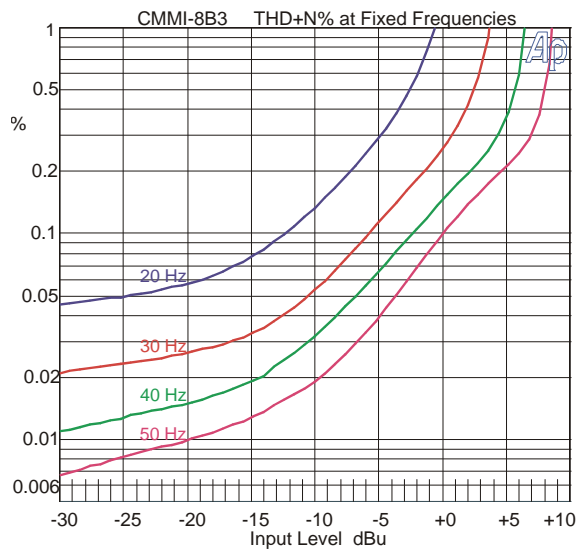
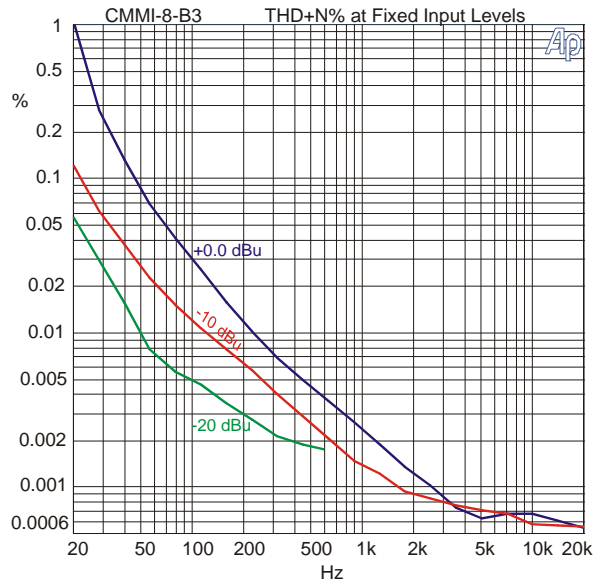
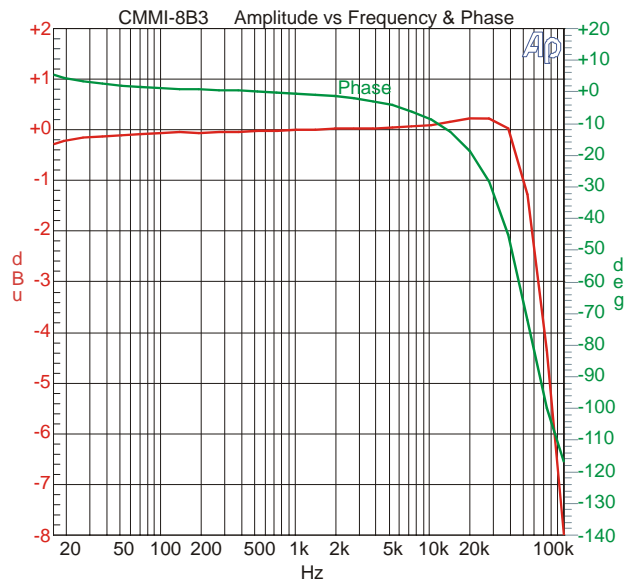

NOTES:

1. All graphs generated from one (1) randomly chosen device. No statistical averaging or weighting. Data from one sweep.
2. R/C snubber optional.

