



Superior Magnetics Since 1979



CMMI-8-PCA

Microphone Input Transformer 1 : 8 Step-up

- Good for bipolar transistor, F.E.T. and tube amplifiers
- Very Good Bandwidth (essentially flat to 60 kHz; -3 dB at 120 kHz)
- Very Good CMRR: 102 dB at 60 Hz
- +18 dB nominal voltage step-up
- Low profile package; pc. mount

The CineMag CMMI-8-PCA is a p.c. mount microphone input transformer which follows classic designs. It is best used with medium to high input impedance amplifiers. It exhibits good bandwidth, common mode rejection ratio (CMRR), and distortion characteristics. The CMMI-8-PCA is a small cost-effective p.c. mount solution and is widely used in professional grade designs. It is encased in a μ Metal can which provides 30 dB of magnetic shielding. As with all CineMag transformers, the wires from the internal foil shields between windings are all spot welded for maximum long term reliability.

The secondary of this transformer has a moderately high impedance. Care must be exercised in the design of the amplifier that it drives to obtain best results and to realize good bandwidth.

CMMI-8-PCA

Parameter	Conditions	Typ
Turns Ratio		1 : 8.00
Voltage Gain	1 kHz, -20 dBu 150 Ω input, 100K secondary load impedance	17.8 dBu
Distortion (THD+N%)	1 kHz, -11 dBu Test circuit 1	0.0015%
	20 Hz, -20 dBu Test circuit 1	0.055%
Max 20 Hz input level	1.0% THD; Test Circuit 1	-2 dBu
Response, ref 1 kHz	20 Hz Test Circuit 1	-0.02 dB
	20 kHz Test Circuit 1	+0.01 dB
	-3 dB 120 kHz	
Phase Shift at 20 Hz	Referenced to source generator	+4°
Phase Shift at 20 kHz	Test Circuit 1	-12°
CMRR	60 Hz Test Circuit 2 per IEEE Std 389-1996 ¶19	102 dB
	1 kHz Test Circuit 2 per IEEE Std 389-1996 ¶19	87 dB
Operating Temp Range	Operation and storage	0° C Min 70° C Max
Max Soldering Temp (p.c.)	5 Seconds	335° C Max

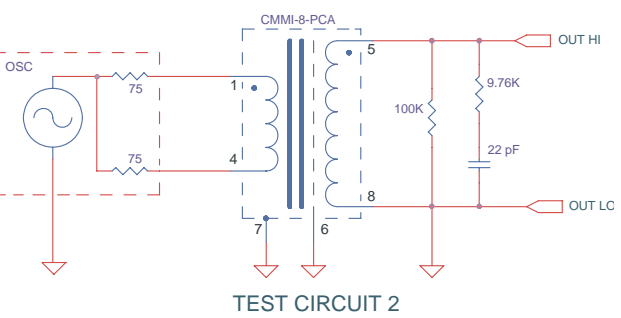
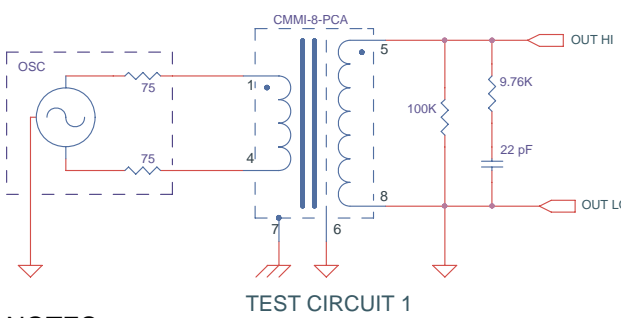
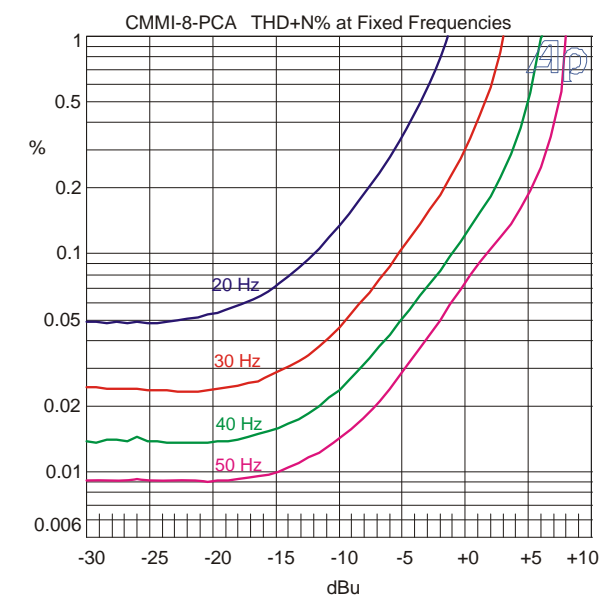
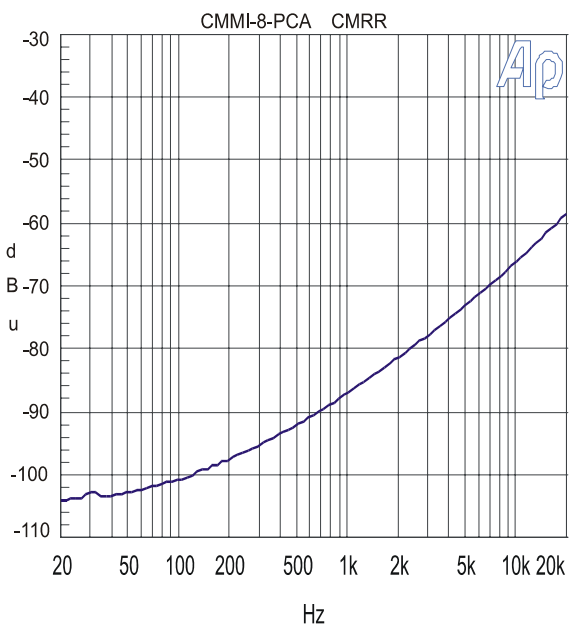
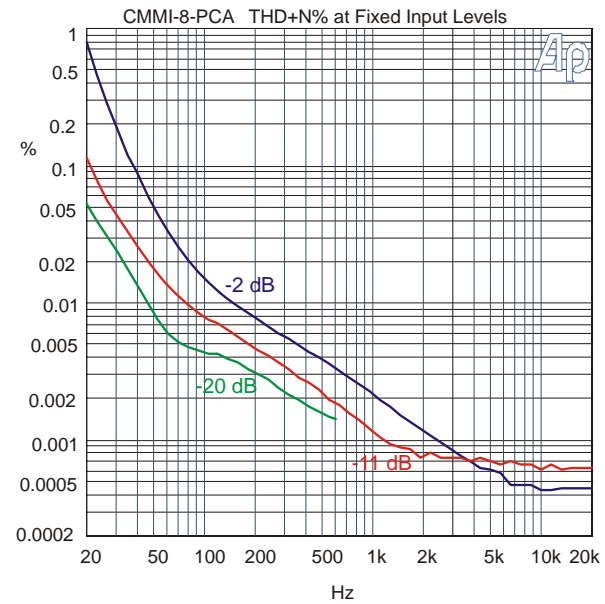
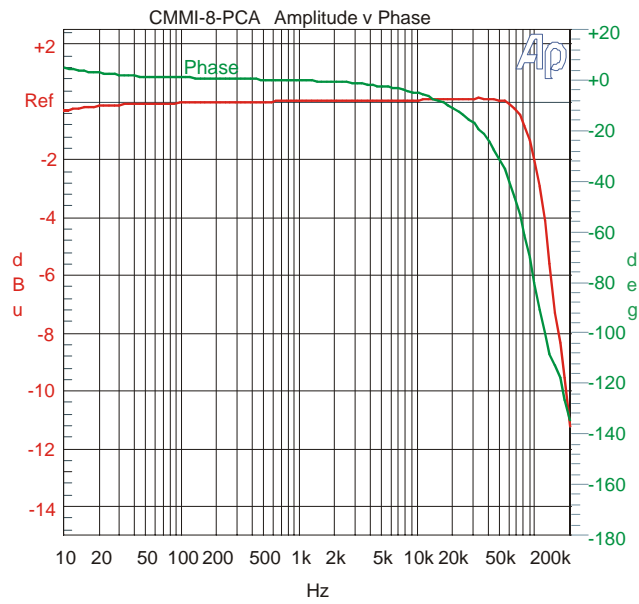

NOTES:

1. All graphs generated from one (1) randomly chosen device. No statistical averaging or weighting. Data from one sweep.
2. R/C snubber optional.

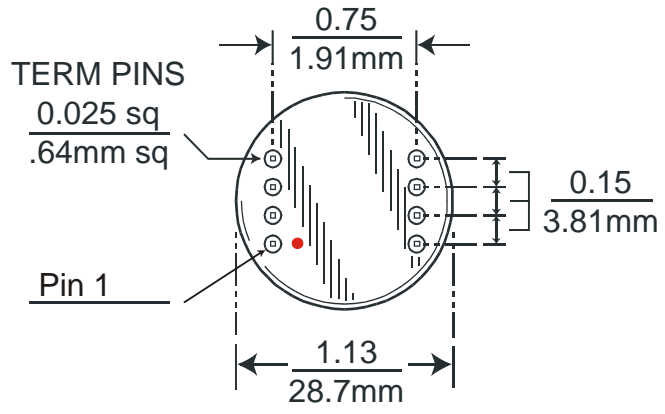
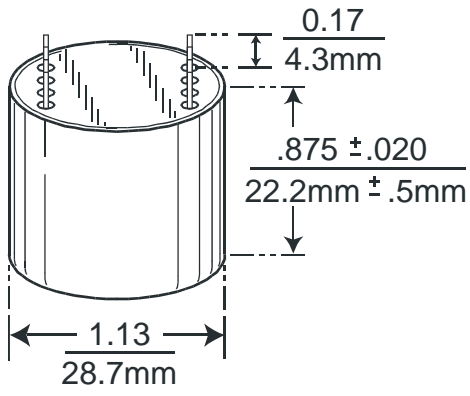

Bottom View