



SUPERIOR MAGNETICS SINCE 1979



# CMMI-10C

## Microphone Input Transformer 1 : 20/10 Step-up

- Recommended for high impedance F.E.T., and tube amplifiers
- 37.5/150:15K impedance ratio
- Very Good Bandwidth
- Very Good CMRR: 102 dB at 60 Hz
- +19.75 dB nominal voltage step-up
- Lead Package or p.c. mount

The CineMag CMMI-10C is designed to take a very high level mic signal before reaching saturation. It is intended to feed a high input impedance amplifier. Having a maximum level at 20Hz of +5dBu, it puts out up to +24.5dBu before reaching core saturation (1% THD at 20Hz). It has very good bandwidth, common mode rejection ratio (CMRR) and distortion characteristics. The CMMI-10C is available with wire leads, or as the CMMI-10CPC it has p.c. pins. It is encased in a *i* metal can which provides 30dB of magnetic shielding. All wires connecting to the internal foil Faraday shields between windings are spot welded for maximum long term reliability, as is done with all CineMag transformers.

NOTE: This transformer has a moderately high impedance secondary. Care must be exercised in the design of the amplifier that it drives to obtain best results and to realize good bandwidth.

CMMI-10-PCA

Parameter	Conditions	Typ	
Turns Ratio		1 : 20.00/10.00	
Voltage Gain	1 kHz, -20 dBu 50/150Ω input, 100K secondary load impedance	19.75 / 39.5 dB	
Distortion (THD+N%)	1 kHz, -2dBu	Test circuit 1	0.004%
	20 Hz, -4dBu	Test circuit 1	0.10%
Max 20 Hz input level	1.0% THD; Test Circuit 1		-3 dB
Response, ref 1 kHz	20Hz	Test Circuit 1	-0.35 dB
	20kHz	Test Circuit 1	+0.2 dB
	-3dB		82 kHz
Phase Shift at 20 Hz	Referenced to source generator Test Circuit 1		+4°
Phase Shift at 20 kHz			-10°
CMRR	60 Hz Test Circuit 2 per IEE Std 389-1996 ¶19		102 dB
	1 kHz Test Circuit 2 per IEE Std 389-1996 ¶19		78 dB
Operating Temp Range	Operation and storage	0° C Min	70° C Max
Max Soldering Temp (p.c.)	5 Seconds		270° C Max

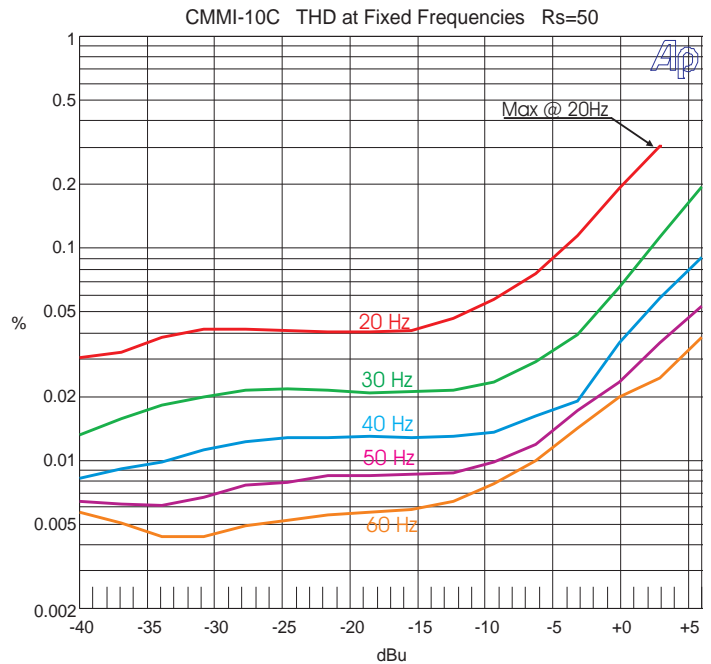
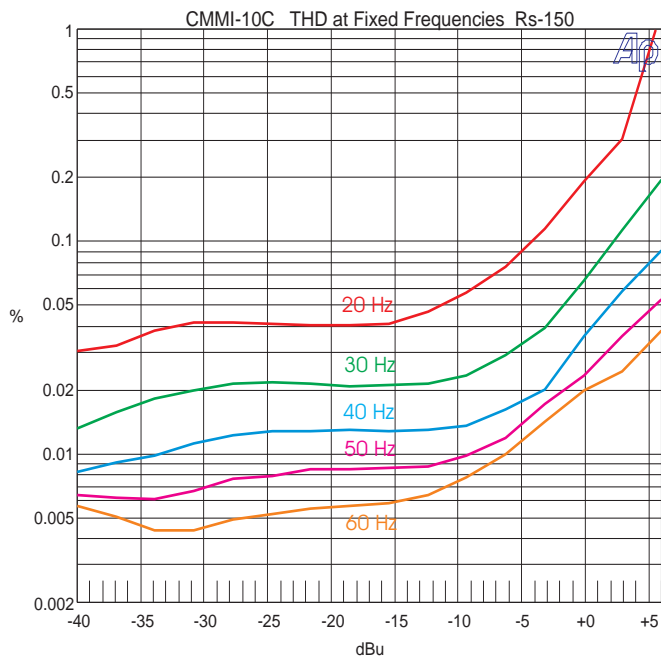
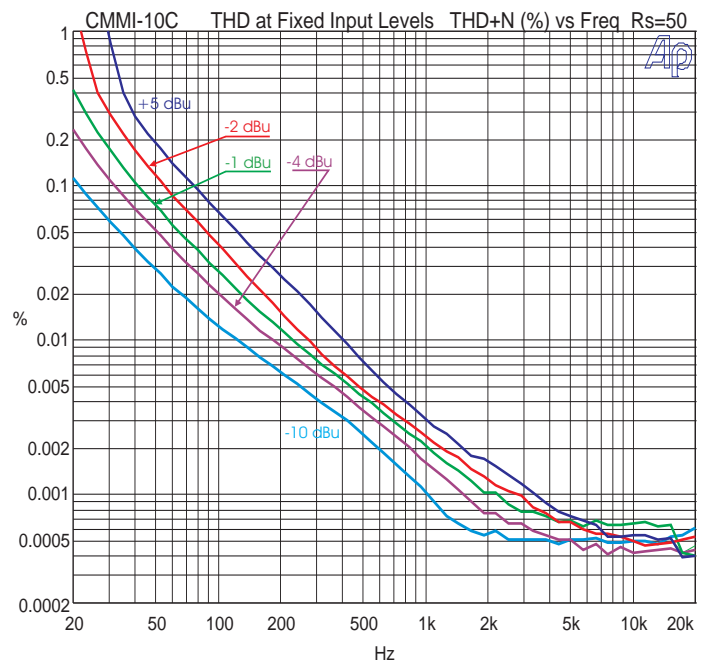
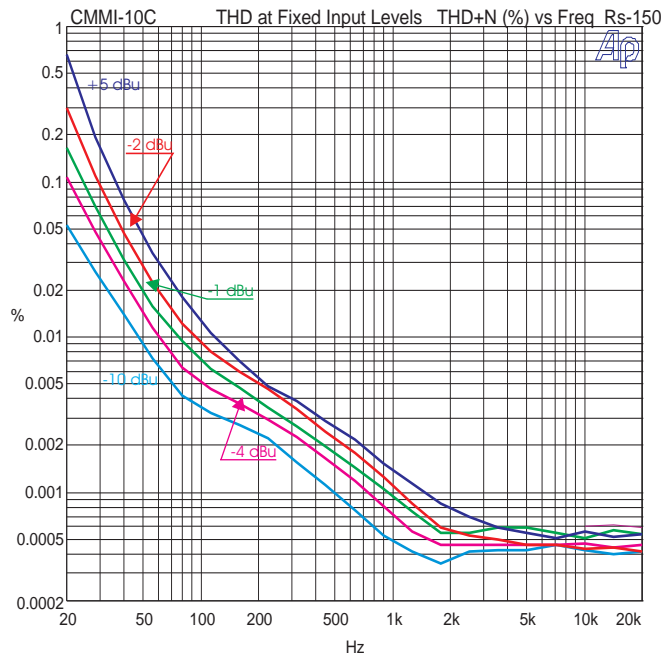
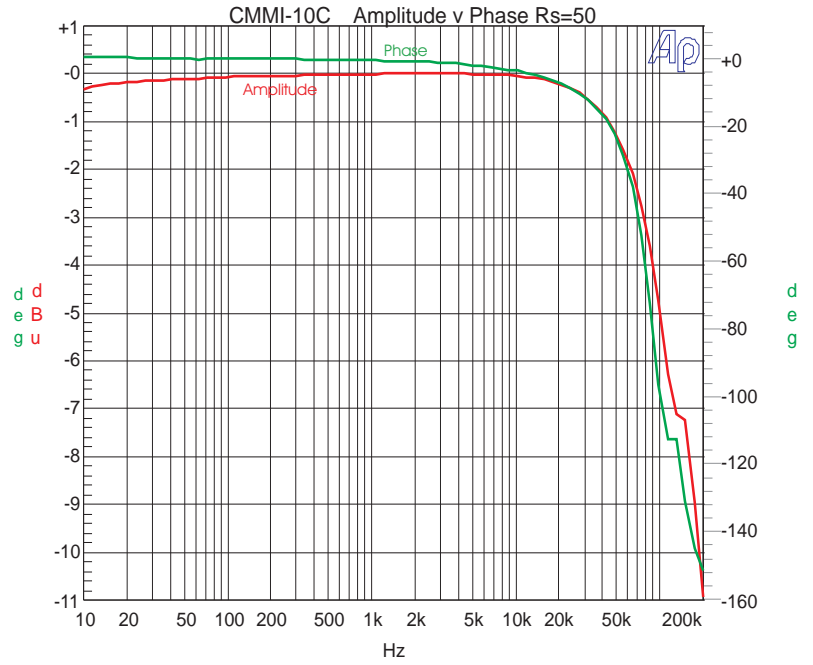
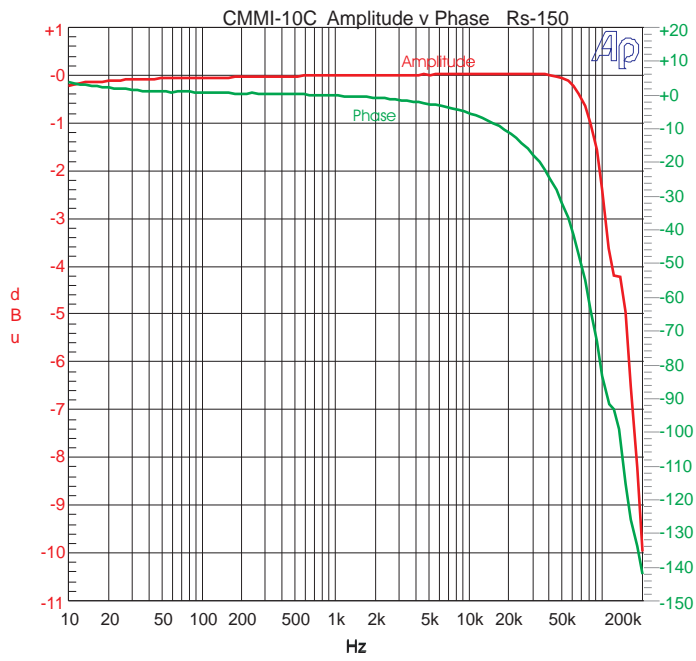

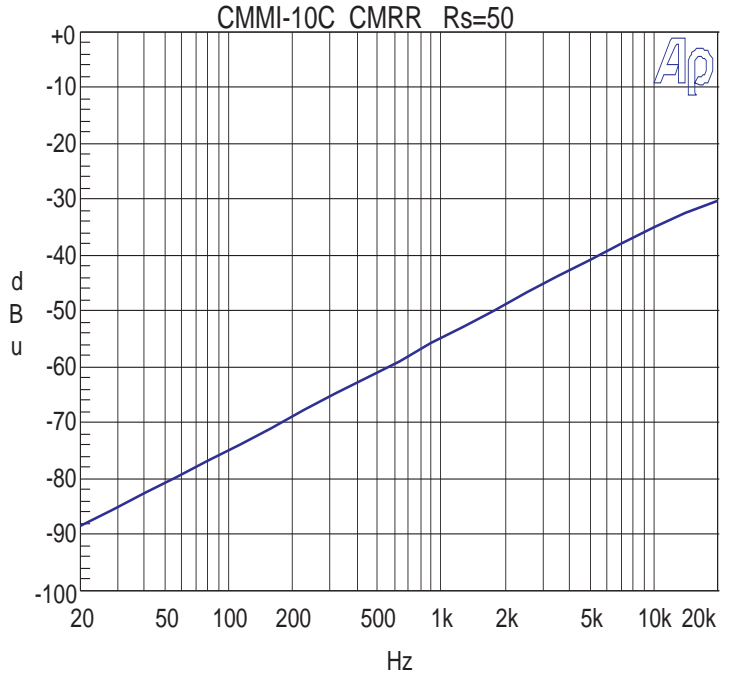
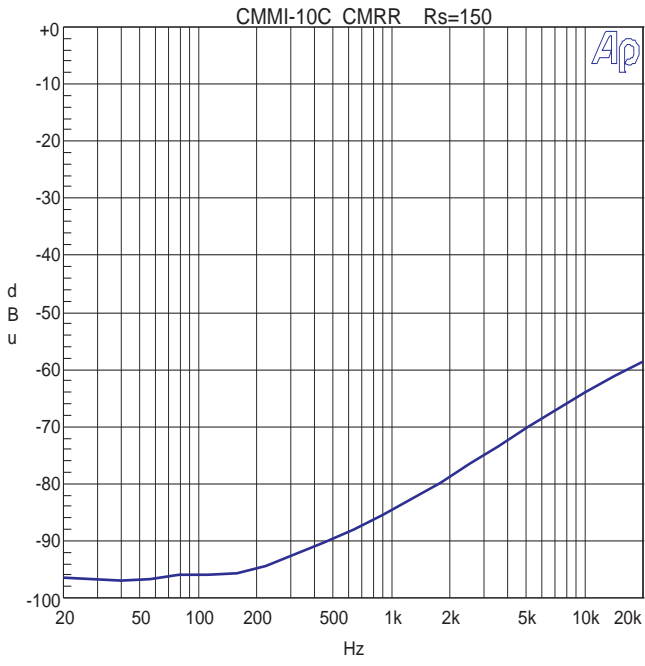

NOTES: 1. All graphs generated from one (1) randomly chosen device. No statistical averaging or weighting. All data from one sweep.

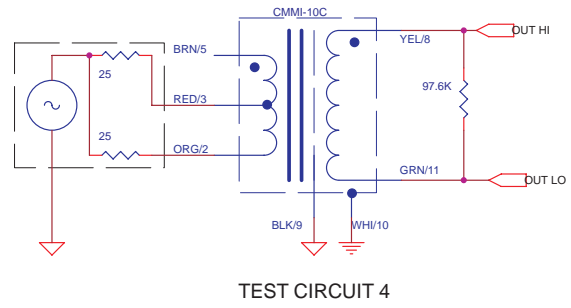
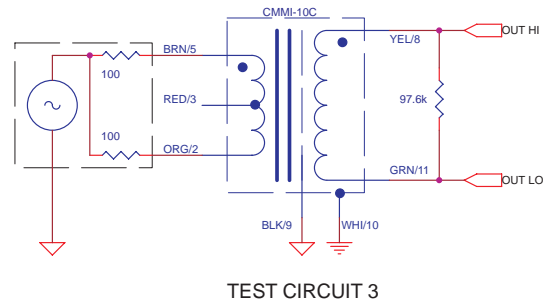
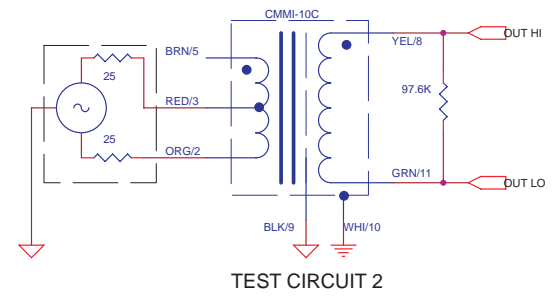
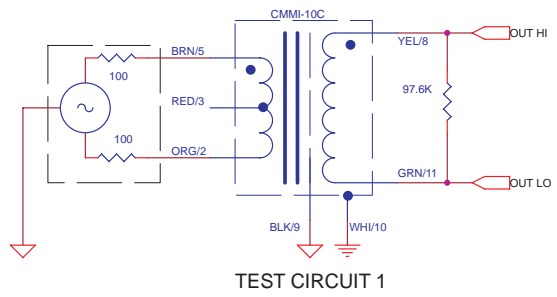

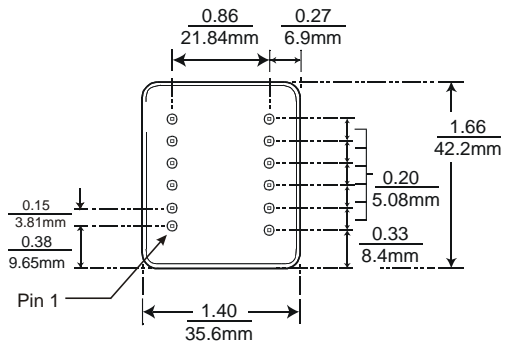
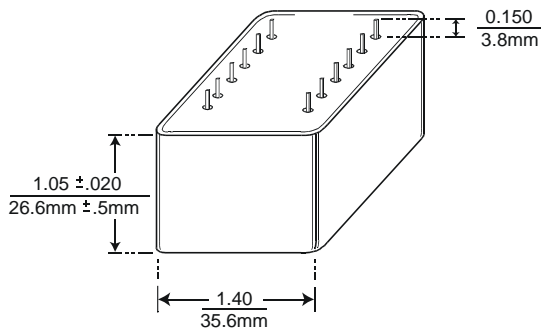
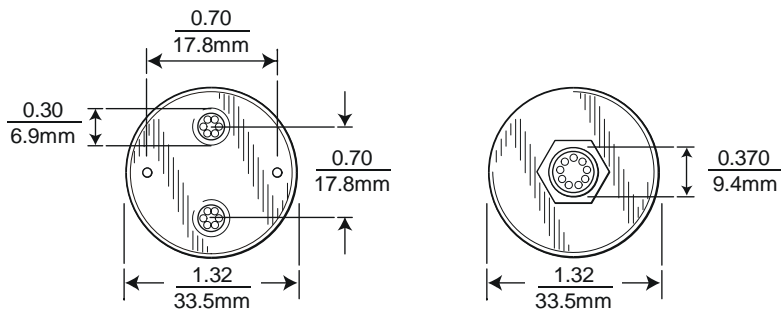
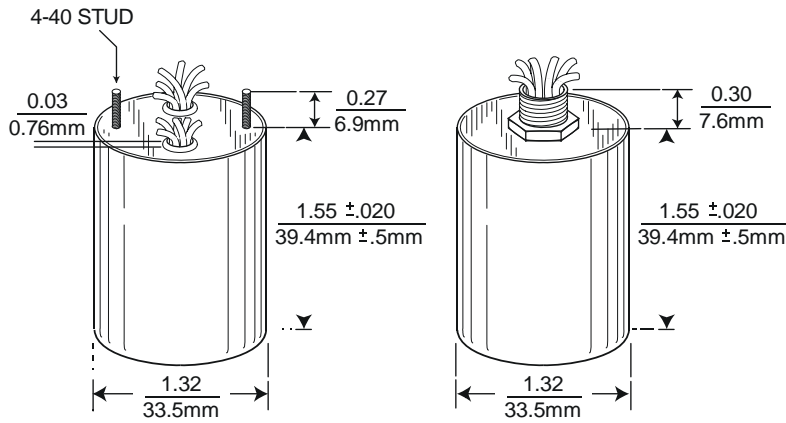

BOTTOM VIEW